

SANDWICH® Valves

Sizes: 4-inch and larger

Manual and hydraulic models available



T.D. Williamson

Bulletin No: **1020.001.04**

Version: 04.2017

Cross Indexing No: n/a

Supersedes: 1020.001.03 (02.2016)

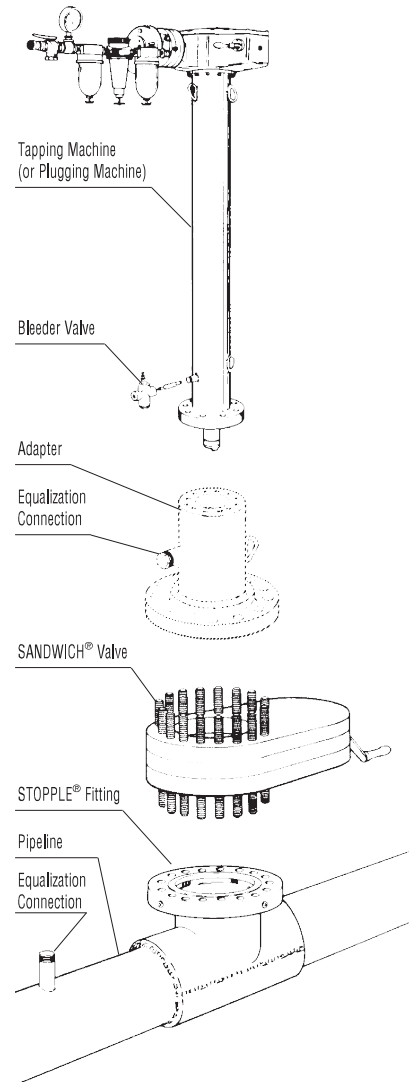
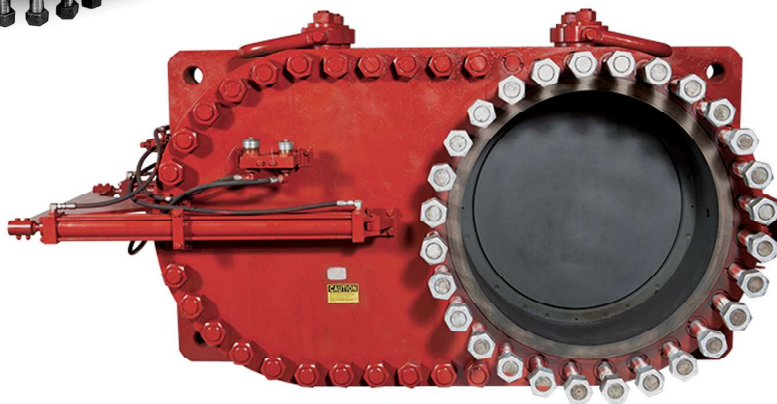
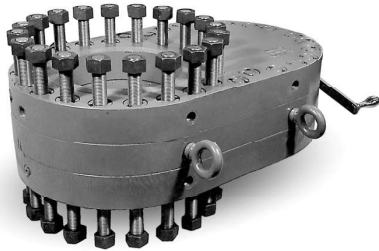

Description

SANDWICH® Valves are designed for use with T.D. Williamson, Inc. Tapping Machines, TDW STOPPLE® Plugging Machines, and fittings with LOCK-O-RING® Flanges during hot tapping and plugging operations. SANDWICH Valves have flat-faced, serrated gasket surfaces and are supplied to match ASME Class 150, 300, or 600 flanges.

SHORTSTOPP® 500 requires the use of 4-through 12-inch ASME Class 300 SANDWICH Valves.

Features

TDW SANDWICH Valves average 75% less total face-to-face dimensions than conventional valves, which means less installation time and easier handling and functioning in tight places where other equipment would be difficult or impossible to use.

The SANDWICH Valve is bidirectional and can be installed on the fitting in any direction as long as the bore of the valve is in line with the fitting bore. The valve can be oriented parallel or perpendicular to the pipeline to fit the excavation.

Other design features of the SANDWICH Valve include an oversized bore, positive shutoff, a built-in pressure equalizing valve and integral flange studs.

Options

TDW is committed to providing you with the exact product to assist you in planning, budgeting and meeting the specifications for your individual application needs. The following options are available:

Sizes 4 in. (100 mm) through 22 in. (558 mm) are hand operated; 24 in. and larger valves are hydraulically operated.



SANDWICH® Valves

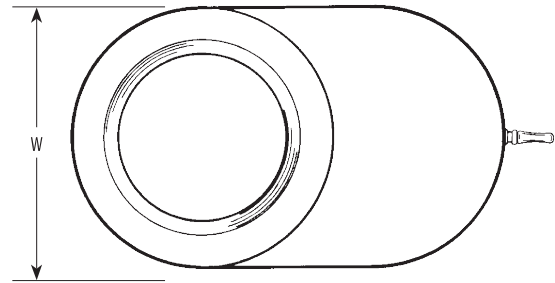
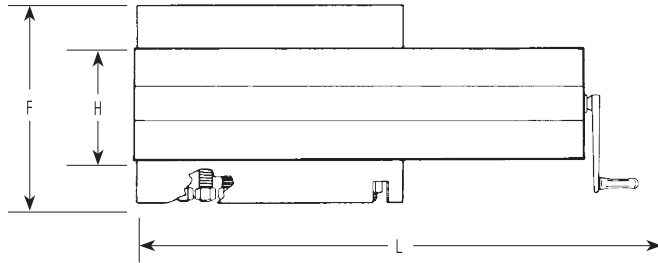

Class 150*

Size		Approx. Weight		W-Width		L-Open		L-Closed		H-Face to Face		F-Overall		Part Number
Inches	mm	Lb.	Kg.	Inches	mm	Inches	mm	Inches	mm	Inches	mm	Inches	mm	
14	350	1150	522	26-1/8	664	38-5/8	981	38-5/8	981	6-1/2	165	13-1/2	343	09-0183-0000
18	450	1650	748	25	635	45-1/8	1146	45-1/8	1146	7-3/4	197	15-1/8	384	09-0513-0000
24	600	3660	1660	32	813	58-1/4	1480	58-1/4	1480	10-3/8	264	19-3/8	492	09-0109-0000
30	750	7050	3198	45-1/4	1149	76-3/8	1940	76-3/8	1940	14-1/2	370	25-7/8	657	09-0867-0000

*Covers bolt pattern only. See Maximum Operating Pressures Chart.

Class 300*

Size		Approx. Weight		W-Width		L-Open		L-Closed		H-Face to Face		F-Overall		Part Number
Inches	mm	Lb.	Kg.	Inches	mm	Inches	mm	Inches	mm	Inches	mm	Inches	mm	
4**	100	153	69	10	254	20-5/8	524	20-5/8	524	4-1/4	108	9-1/4	235	09-0097-0000
6**	150	260	118	12-1/2	318	25	635	25	635	5-1/2	140	10-1/4	260	09-0077-0000
8**	200	415	188	15	381	29-1/2	749	29-1/2	749	5-7/8	149	11-1/8	283	09-0064-0000
10**	250	750	340	17-1/2	445	34-3/8	873	34-3/8	873	7	178	13	330	09-0106-0000
12**	300	1150	522	20-1/2	521	39-5/8	1006	39-5/8	1006	7-5/8	194	14-1/4	362	09-0066-0000
14	350	1600	726	23	584	38-1/2	978	38-1/2	978	7-3/4	197	16	406	09-0512-0000
18	450	2320	1050	28	911	47-1/2	1207	47-1/2	1207	10-1/8	251	18-3/4	476	09-0515-0000
20	500	3200	1452	30-1/2	775	56-3/4	1441	56-3/4	1441	10-5/8	270	19-1/8	486	09-0738-0000
22	550	4800	2177	30-1/2	775	52-1/2	1334	52-1/2	1334	10-5/8	270	20-1/8	511	09-0511-0000
24	600	5300	2404	36	914	96	2438	72-3/8	1838	12-3/4	324	22-3/4	578	09-0052-0000
36	900	15500	2031	50	1270	138-3/4	3524	102	2591	9-9/16	497	32-13/16	833	09-0079-0000

*Covers bolt pattern only. See Maximum Operating Pressures Chart.

**For use with 4- through 12-inch SHORTSTOPP® 500



SANDWICH® Valves

Class 600*

Size		Approx. Weight		W-Width		L-Open		L-Closed		H-Face to Face		F-Overall		Part Number
Inches	mm	Lb.	Kg.	Inches	mm	Inches	mm	Inches	mm	Inches	mm	Inches	mm	
4	100	177	80	10-3/4	273	21-3/8	543	21-3/8	543	5	127	10-3/4	273	09-0096-0000
6	150	450	204	14	356	26-1/8	664	26-1/8	664	6-1/2	165	13-1/2	343	09-0061-0000
8	200	575	261	16-1/2	419	31-3/8	797	31-3/8	797	7-1/8	181	14-7/8	378	09-0060-0000
10	250	950	431	20	508	37-1/4	946	37-1/4	946	8	203	16-1/2	419	09-0067-0000
12	300	1500	680	22	559	41	1041	41	1041	9-15/16	252	18-1/2	470	09-0058-0000
16	400	3000	1361	27	686	48-5/8	1235	48-5/8	1235	11-3/4	298	21-3/4	552	09-0054-0000
18	450	3750	1700	29-1/4	743	54	1372	54	1372	13-5/16	338	24	610	09-0063-0000
20	500	4700	2132	32	813	57-5/8	1464	57-5/8	1464	13-3/4	349	24-7/8	632	09-0029-0000
22	550	6200	2812	34-1/4	870	62-1/8	1578	62-1/8	1578	13-3/4	349	25-7/8	651	09-0543-0000
24	600	6300	2858	37	940	102-1/8	2594	76-1/8	1934	13-7/8	352	26-5/8	676	09-0162-0000
26	650	8500	3856	40	1016	105	2667	78-1/4	1988	16-1/4	413	30	762	09-0134-0000
30	750	11300	5126	53-1/4	1353	114-1/8	2899	84	2134	17-3/4	451	35	889	08-0584-0000
34	850	15500	7031	49	1245	134-3/8	3413	98-3/8	2499	19-7/8	505	35-3/8	898	09-0156-0000
36	900	23000	10433	51-3/4	1314	140-3/4	3575	104	2642	25-1/2	648	41-3/4	1060	09-0716-0000
40	1000	27250	--	57-1/8	1450	153	3886	114	2896	22-5/8	575	41-5/8	1057	09-0506-0000
48	1200	32500	14742	64	1626	175-3/4	4464	127	3226	22-9/16	573	45	1143	09-0536-0000

*Covers bolt pattern only. See Maximum Operating Pressures Chart.



SANDWICH® Valves

Maximum Operating Pressures**

Class	PN	4- through 20-inch (100- through 500-mm)		22- through 36-inch** (550- through 900-mm)	
		psi	bar	psi	bar
150	20	275	20	275	20
300	50	720	50	720	50
400	64	960	64	720	50
600	100	1200	83	900	62
40 in. (1000 mm)					
400	64	600	41		

**Note: 22- through 36-inch (550- through 900-mm) Class 600 (PN 100) SANDWICH® Valve ordered from and manufactured by TDW (UK) in England and TDW (S.A.) in Belgium have a standard maximum operating pressure of 1000 psi (70 bar).

IMPORTANT: Contact factory for bolt circle dimensions for sizes above 36 inch.

Full Rated ASME Class 600 SANDWICH® Valves

Nom. Size		Approx. Weight		W-Width		L-Open		L-Closed		H-Face to Face		F-Overall		Part Number
Inches	mm	Lb.	Kg.	Inches	mm	Inches	mm	Inches	mm	Inches	mm	Inches	mm	
8	200	630	286	16.5	420	34.62	880	34.62	880	9.19	234	17.25	438	09-0702-0000
10	250	1400	635	20.0	508	39.88	1013	39.88	1013	10.44	266	19.25	489	09-0703-0000
12	300	1900	862	22.0	559	44.00	1118	44.00	1118	11.31	288	20.50	521	09-0704-0000
14	350	2400	1089	23.75	604	45.75	1162	45.75	1162	11.94	304	21.75	553	09-0705-0000
16	400	3500	1588	27.00	686	49.88	1267	49.88	1267	13.06	332	23.40	595	09-0706-0000
18	450	4100	1860	29.25	743	54.13	1375	54.13	1375	13.88	353	25.00	635	09-0707-0000
20	500	5090	2309	32.00	813	58.88	1496	58.88	1496	14.94	379	26.50	673	09-0708-0000
22	550	6250	2835	34.25	870	63.75	1620	63.75	1620	16.09	409	28.00	712	09-0709-0000
24	600	8300	3765	37.00	940	107.13	2721	82.00	2721	17.38	442	30.50	775	09-0710-0000
30	750	14000	6351	44.50	1131	128.50	3264	97.38	3264	20.94	532	36.00	915	09-0713-0000
34	850	18500	8392	49.00	1245	141.00	3582	105.88	3582	23.19	587	39.00	991	09-0715-0000
36	900	20000	9072	51.75	1315	147.75	3753	110.62	3753	24.44	621	41.00	1042	09-0716-0000

The above SANDWICH® Tapping Valves are fully rated to 1480 psi @ 100° F and are compatible with NACE MRO 1-75 applications. They also feature a raised-face flange design. Consult factory for other sizes.